

2016

二 形

2015

1.

2015 7

2.

100%

.....	1
.....	2
.....	2
.....	3
.....	6
.....	6
.....	8
.....	9
.....	15
.....	20
.....	20
.....	20
.....	20
.....	21
.....	21
.....	22
.....	24
.....	27
.....	27
.....	38
.....	40
.....	40
.....	40
.....	47
.....	51
.....	52
.....	52
.....	53
.....	54
.....	55
.....	55
.....	59

.....	62
.....	62
.....	62
.....	62
.....	63
.....	63
.....	65
.....	66
.....	69
.....	69
.....	72
.....	73
.....	73
.....	73
.....	80
.....	81
.....	82

2015 34

2015

7

2014 180

(2008 196)

2007 14

2012 1

2010 4

2007 14

2008 196

2008 196

2007 14

2012 108

1:500



- ★
- ★
- ★
- ★

[2015]7

2012 1

EXCEL

<https://sls.cdb.com.cn/preapply>

6 15

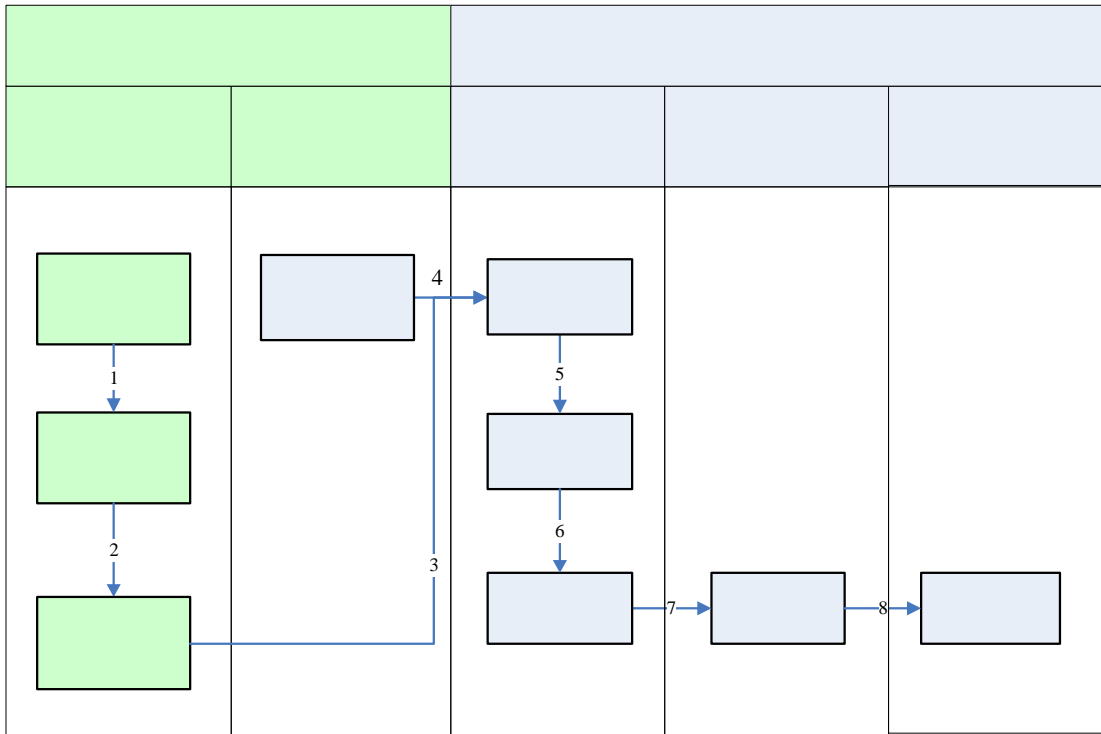

1



★

★

6 15

EXCEL



★

★

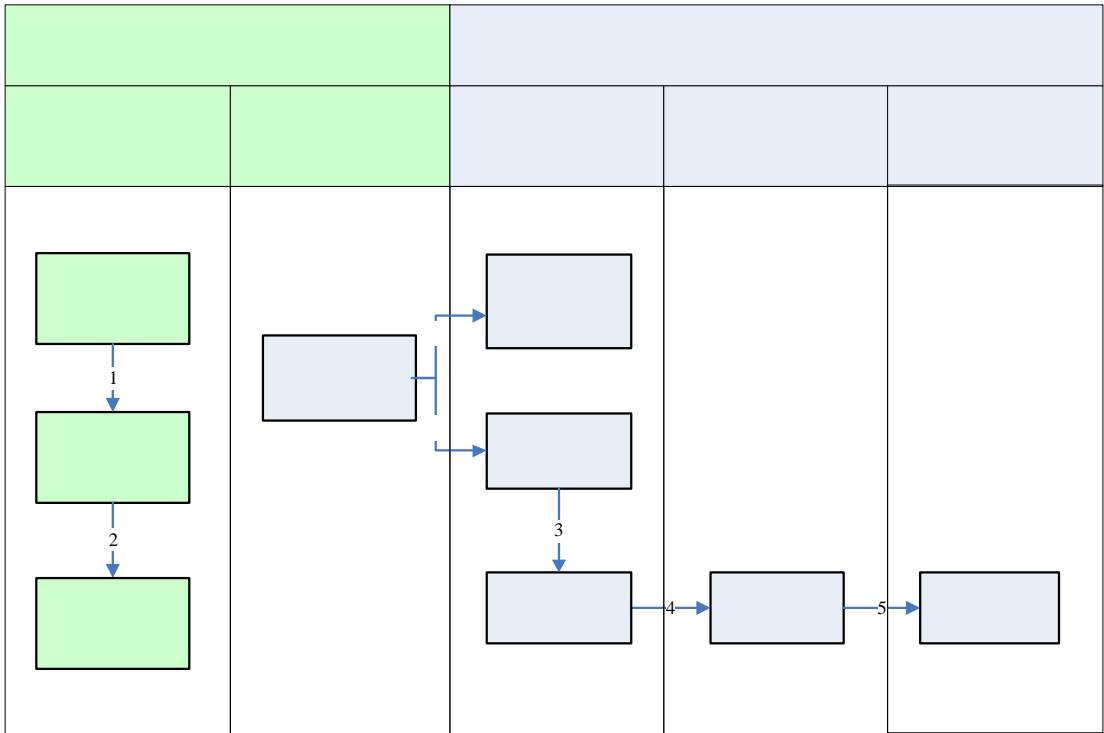

2

- 1.
- 2.
- 3.

4.

5.

6.

1.

2.

3.

4.

5.

6.

25

60

1000

8000

8000

12000

1000

12000

13

5

20

13

1

1

2.

< >

2



3.帶

U

2

1.

6 30

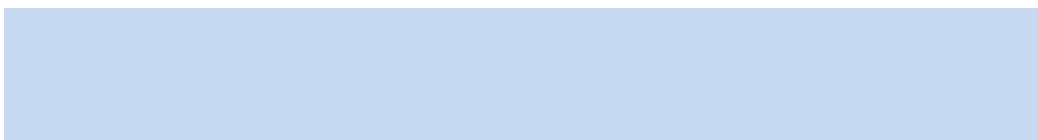

2.

3.

6

-





★

★



★

★

★

★

★

1.

2.

“ ”

631

5



10 10 10 10



- ★
- ★
- ★



- ★
- ★
- ★

3

1. 10 10



2.10 15

3.

4. 3



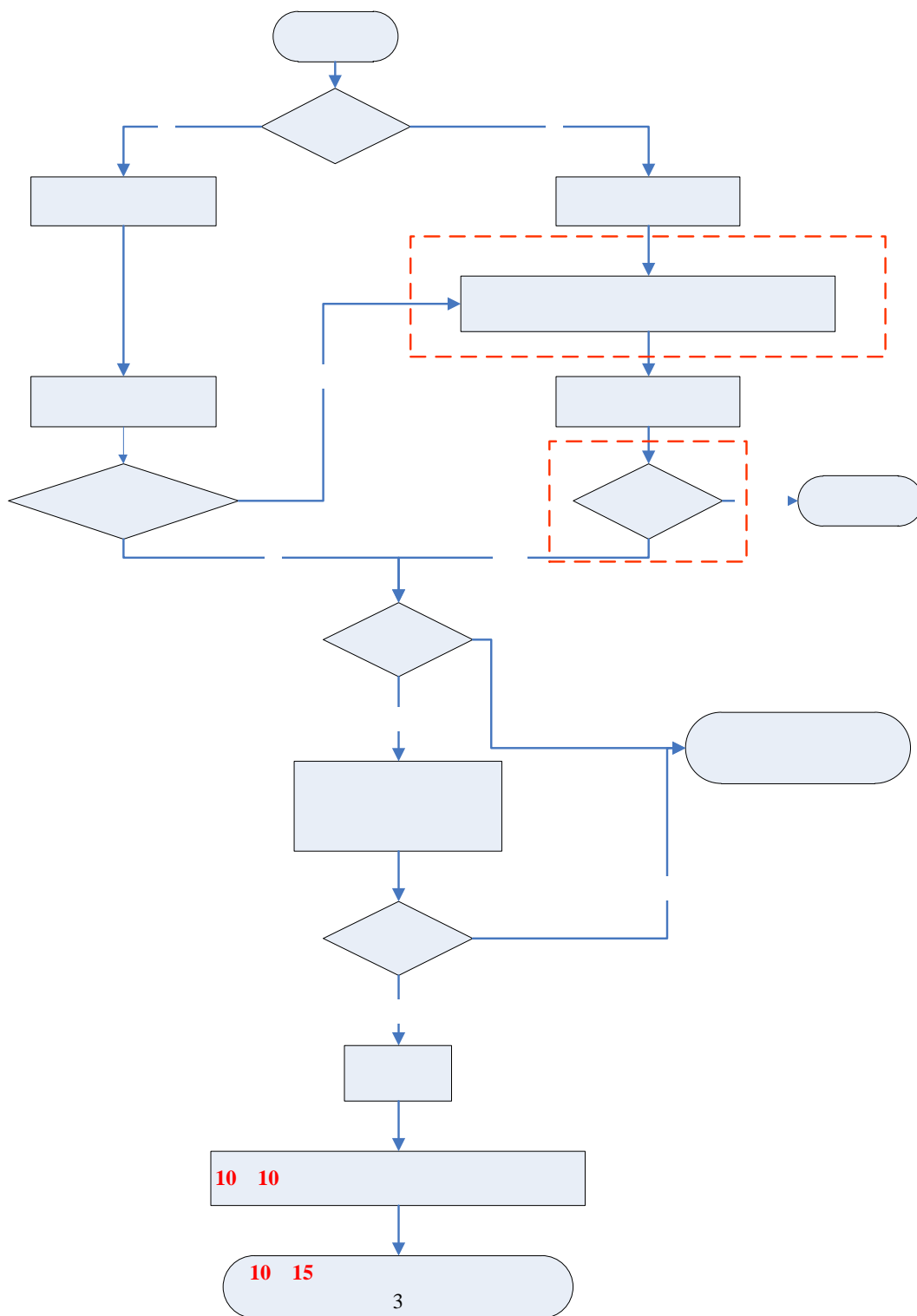

3

4

5

1

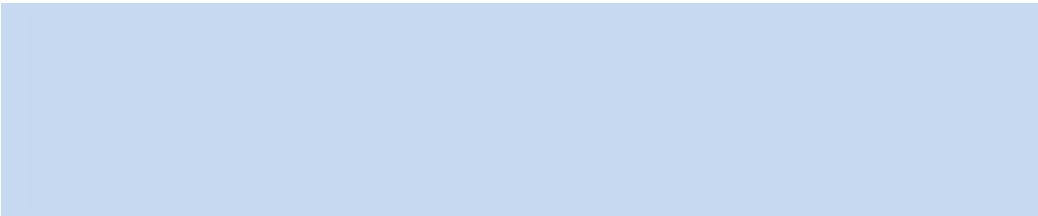

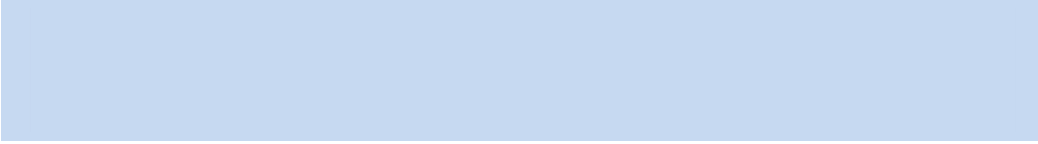

XXX

4 6

6

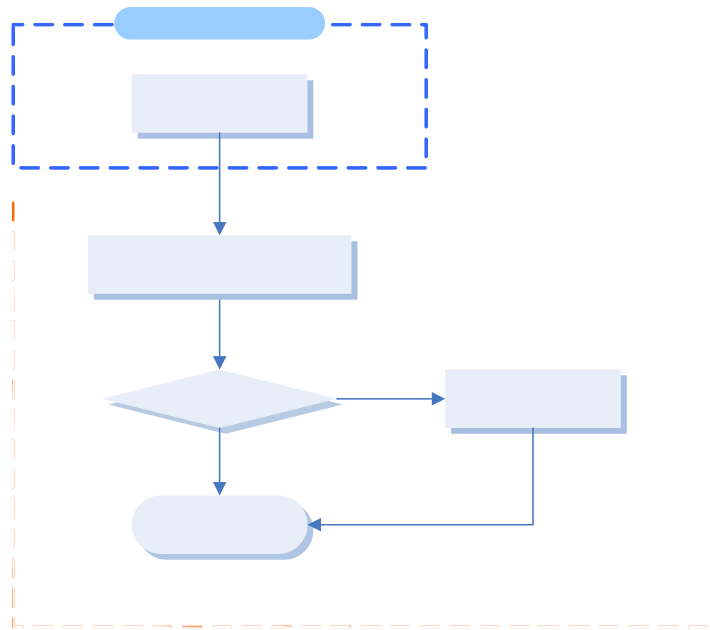

4



7



8



12 20

9 20

12 15

11

20

1 9 12 15

20 15

20 10 1

15

10 20 10 16 11 30

12 20

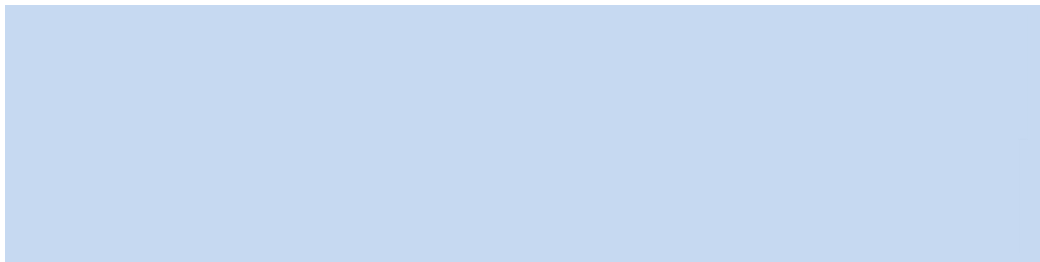

20

❖

16

7000

5

4.9%

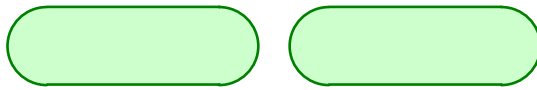

5

1 1

1 31

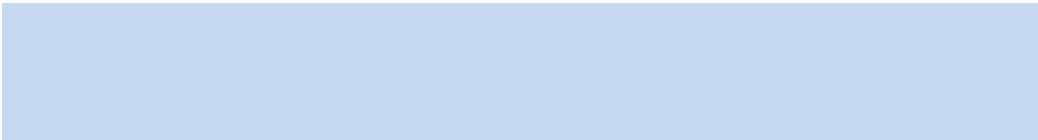

1.

2.

3.

POS

POS

90

90

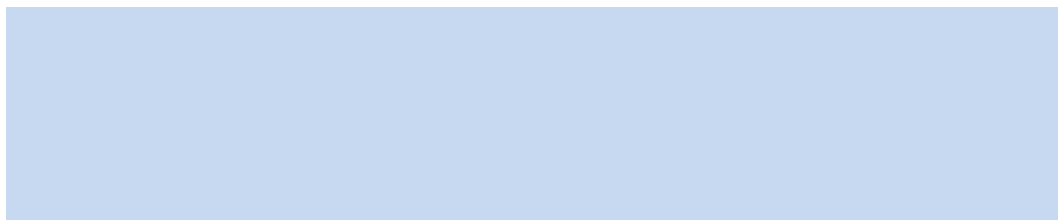

1.

2.

3.

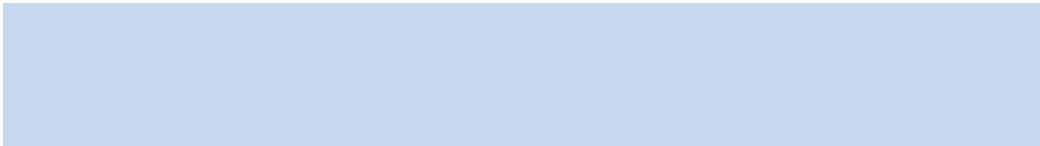



1. <https://www.alipay.com>



2.



3.



7.



8.

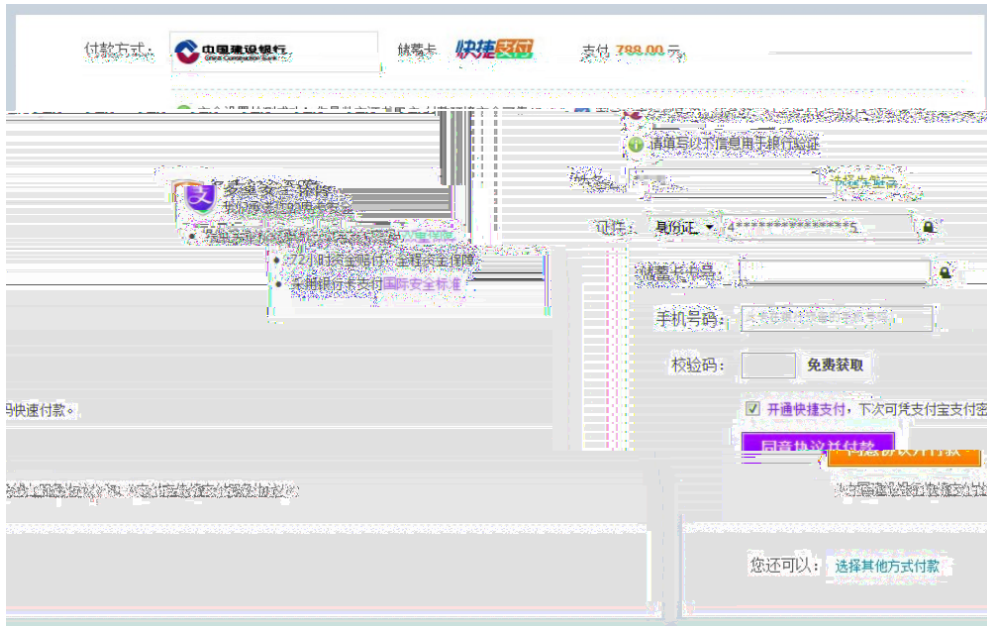

9.

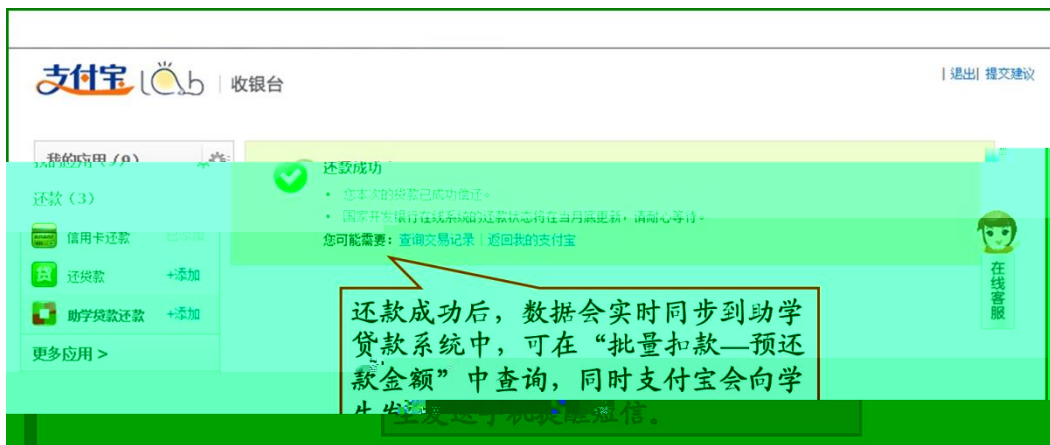

1.



2.



3.

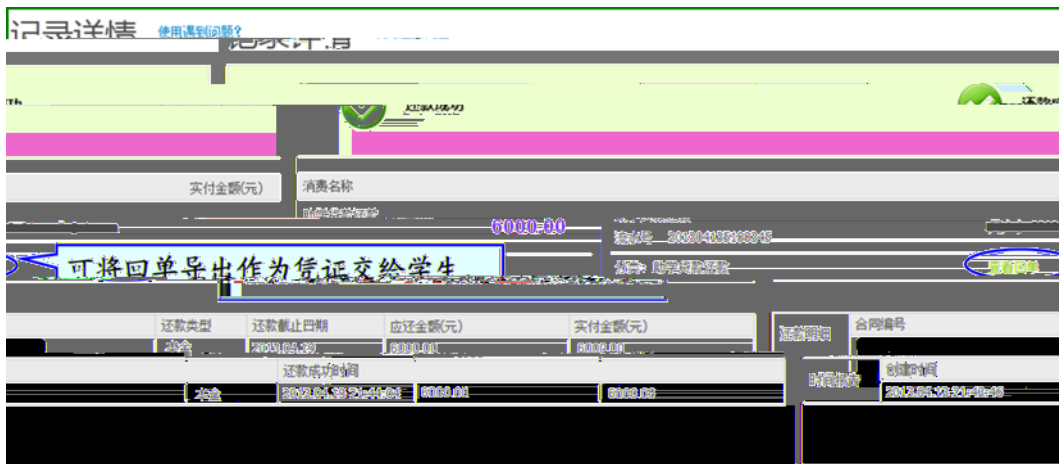

4.



POS

POS

POS

POS

1

POS

POS

1

POS

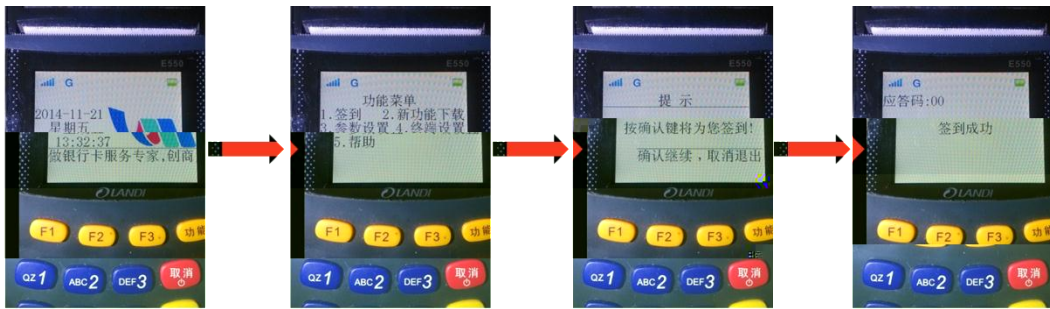

1. 开机，进入POS机主页面。
 2. 按“功能”键打开菜单，选择“签到”。
 3. 根据提示按“确认”键进行签到。
 4. 更新数据，片刻后显示签到成功。

2



1. 在主页面按“确认”键，打开功能菜单，选择“助学贷款还款”。
 2. 进入业务类型菜单，选择“生源地助学贷款”。
 3. 进入身份证号录入页面。

3

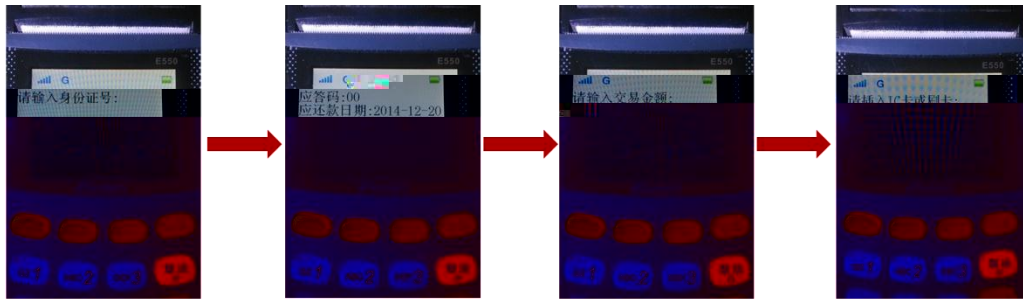

1. 输入身份证信息，核实无误后按“确认”。
 2. 核对并显示还款信息，核实无误后按“确认”。
 3. 显示本次应还款金额（不可修改），核实无误后按：“确认”。
 4. 进入刷卡页面。

4

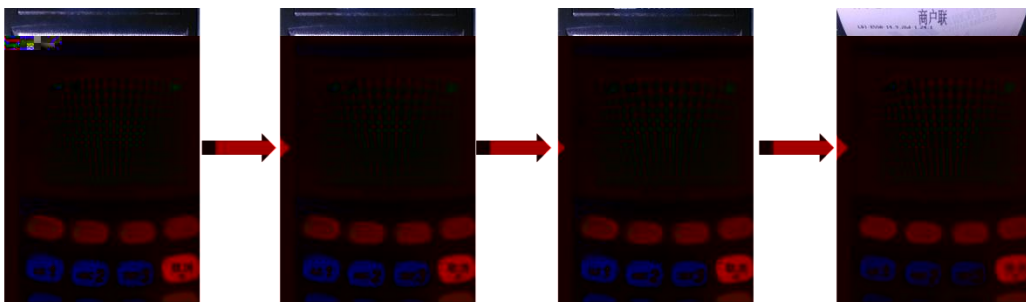

1. 刷卡后显示卡号信息，核实无误后按“确认”。

2. 输入密码，核实无误后按“确认”。

3. 完成数据核对和处理后，显示还款结果。

4. 还款成功后，按“确认”打印小票。

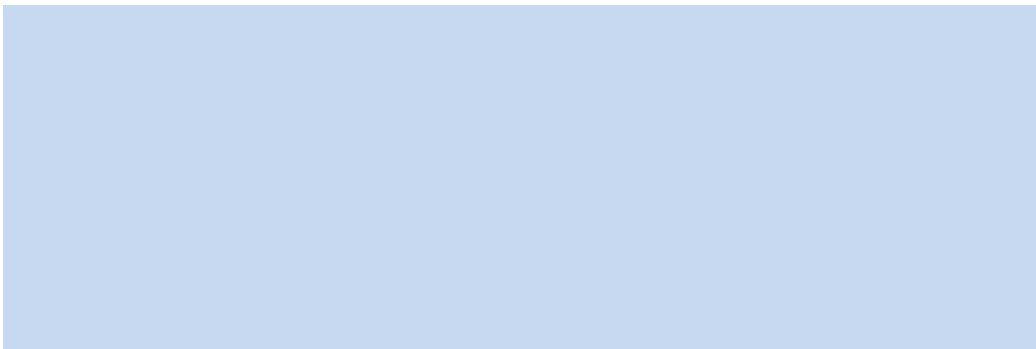

12 20

xx

xx

11 30

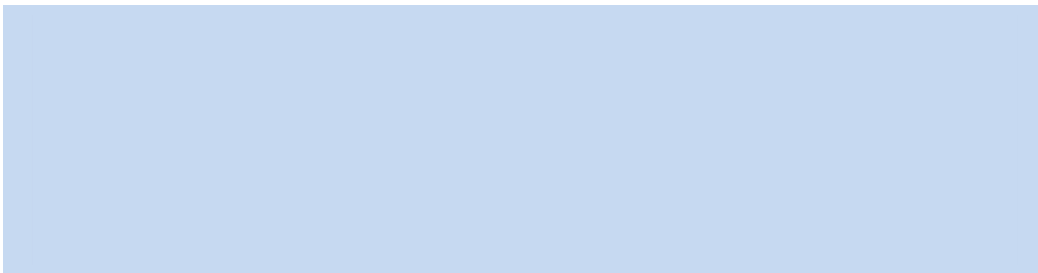

15%

- 1.
- 2.
- 3.
- 4.

3

2

3

1.

2.

3.

A4

1

1



zxdk

/

4

11-13



1



8

20140801

:

15

44

XX

XX



8

20140801



1



1.

2.

3.

3

5

11-13

1

3

3 1

2

1

5

1.

A4

2.

3.

A4

2

2004 51

1.

2.

2004 51



3.



1.

1:2500

AB

B

A

A

2.



[2015]7

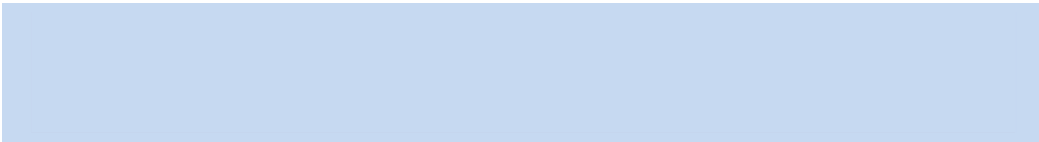

- 1.
- 2.

3.

4.

5.

6.



★

★

1.

2.

3.

4.

5.

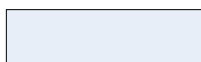
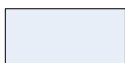
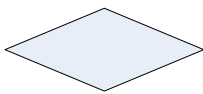
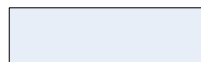
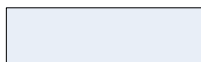
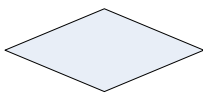

6



15

<

>



帶

U

15

1.

2.



★ 帯

★



16

3

1

10 15

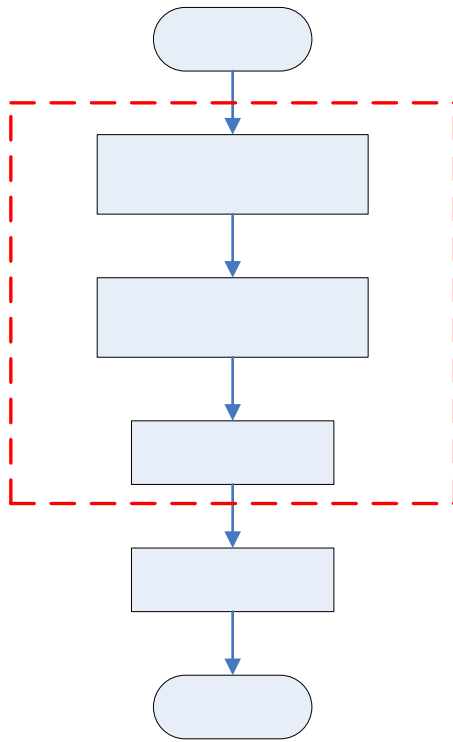

7

17

18

1

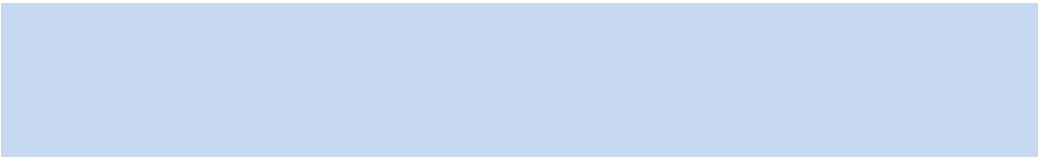

QQ

1.

2.

3.

4 6

19



11 1

95593

65

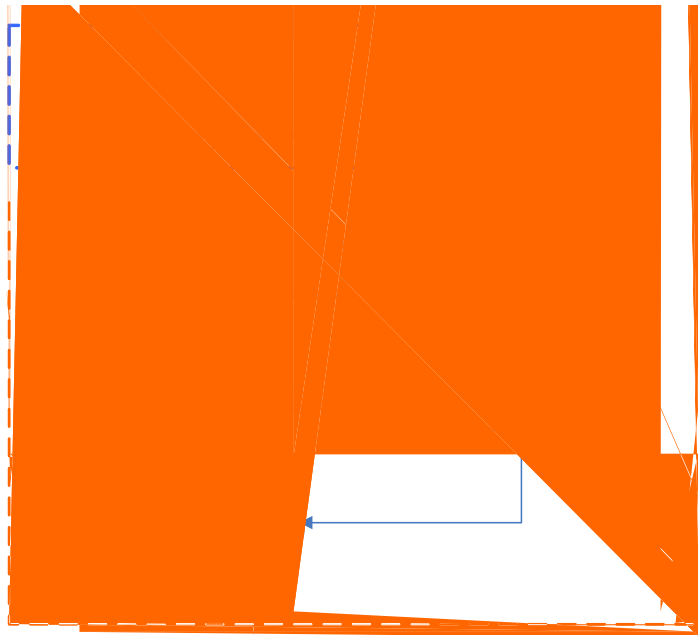



20



21

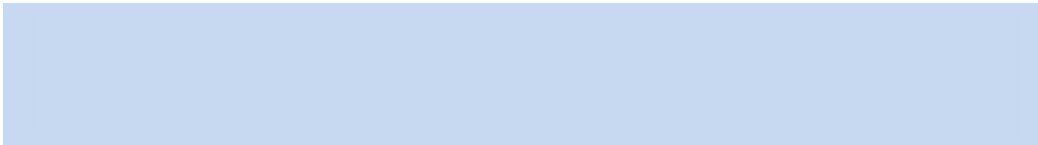

22





23



24

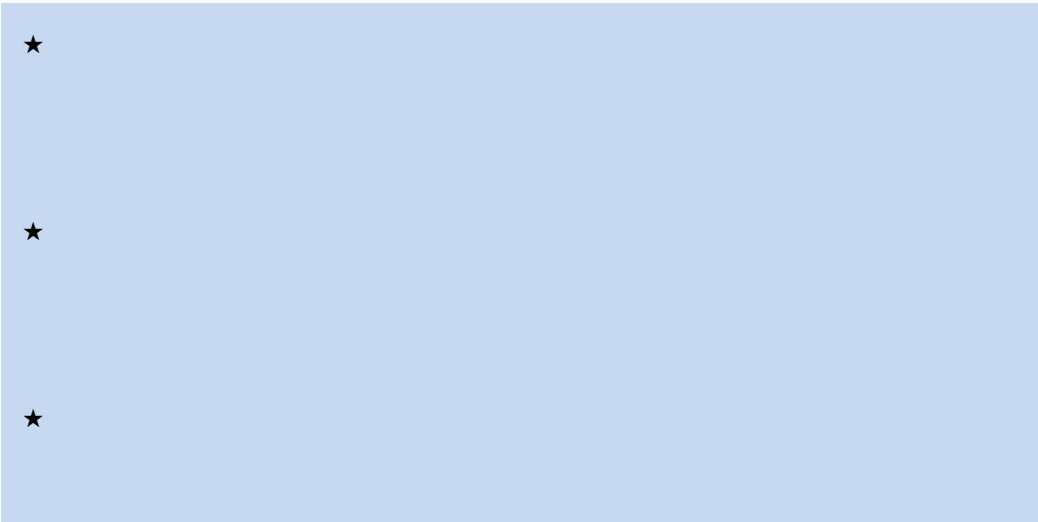

12 20

9 20

1

11

20

1 9 12 15

20 15 20 10 1

15 10 20 10 16 11 30

12 20

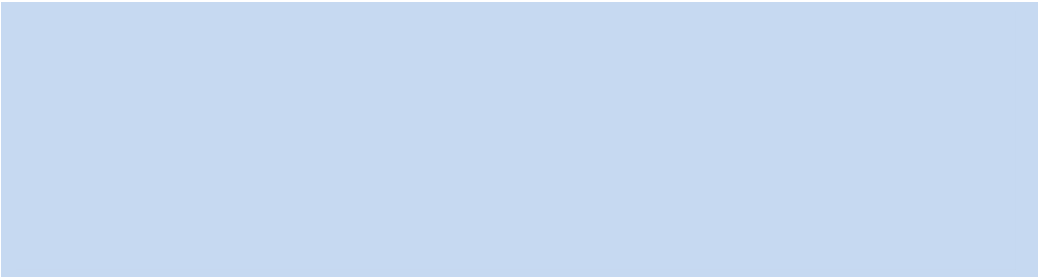



9

1 1

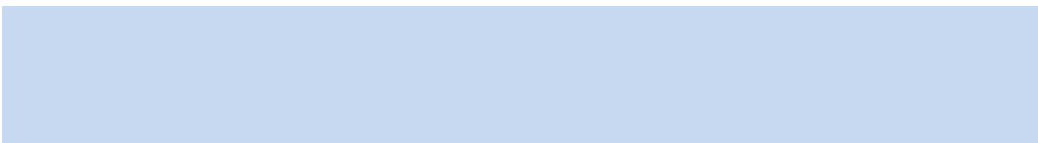

1.

20

2.

3.

90

90

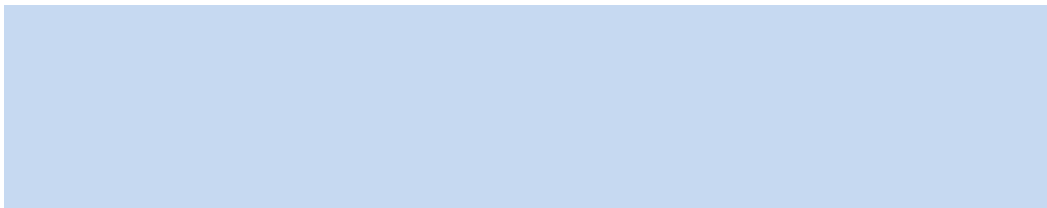

1.

2.

71

3.

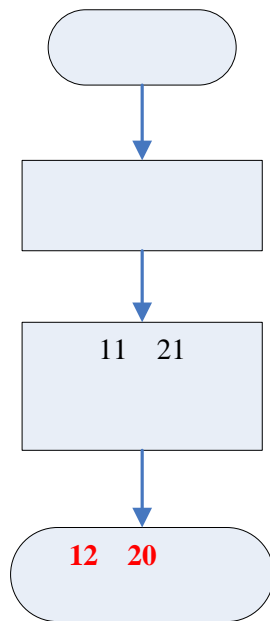

10



12 20

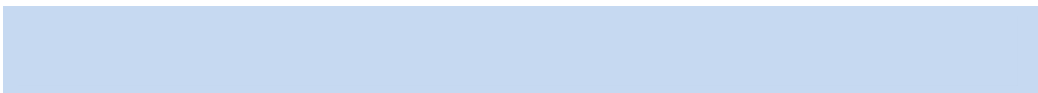

12 20

9 1

8 31

1.

2.

3.

4.

3

5

1					
2					

3					
4					
5					
6					
7					
8					
9					

6

1					
2					
3					
4					
5					
6					

7					
8					
9					

10

1

❖ - 4
❖ 5
❖ 4 2014
❖ 2

12345/2014/06/29-1

25

❖

1



8

20140801

15



1



1. 2015 34
2. 2015 7
3. 2014 180
4. (2008 196)
5. 2012 1
6. 2007 14
7. 2010 4
8. < 2014 16 >
9. 2004 51

<http://zxdk.cdb.com.cn>

www.gbms.cdb.com.cn U

www.csls.cdb.com.cn

<https://sls.cdb.com.cn/preapply>